

## POLE BUILDING REQUIREMENTS

As required by Bureau Veritas North America, Inc.

All information below and on the other side must be provided. Each item should be checked off and this form must be returned with the application.

- Application.
- Local Municipal Approval
- Site plan or provide setbacks. (Be sure to include all structures on the property)
- Two full sets of plans. (Must be in ink and drawn to scale)

**THIS COMPLETED FORM ALONG WITH THE REVERSE SIDE MUST BE  
TURNED IN WITH PLANS**

# Pole Building Cross Section Submittal

- 1. Building Size: Length \_\_\_\_\_ x Width \_\_\_\_\_
- 2. Draw Floorplan: Show All Post & Beam Locations

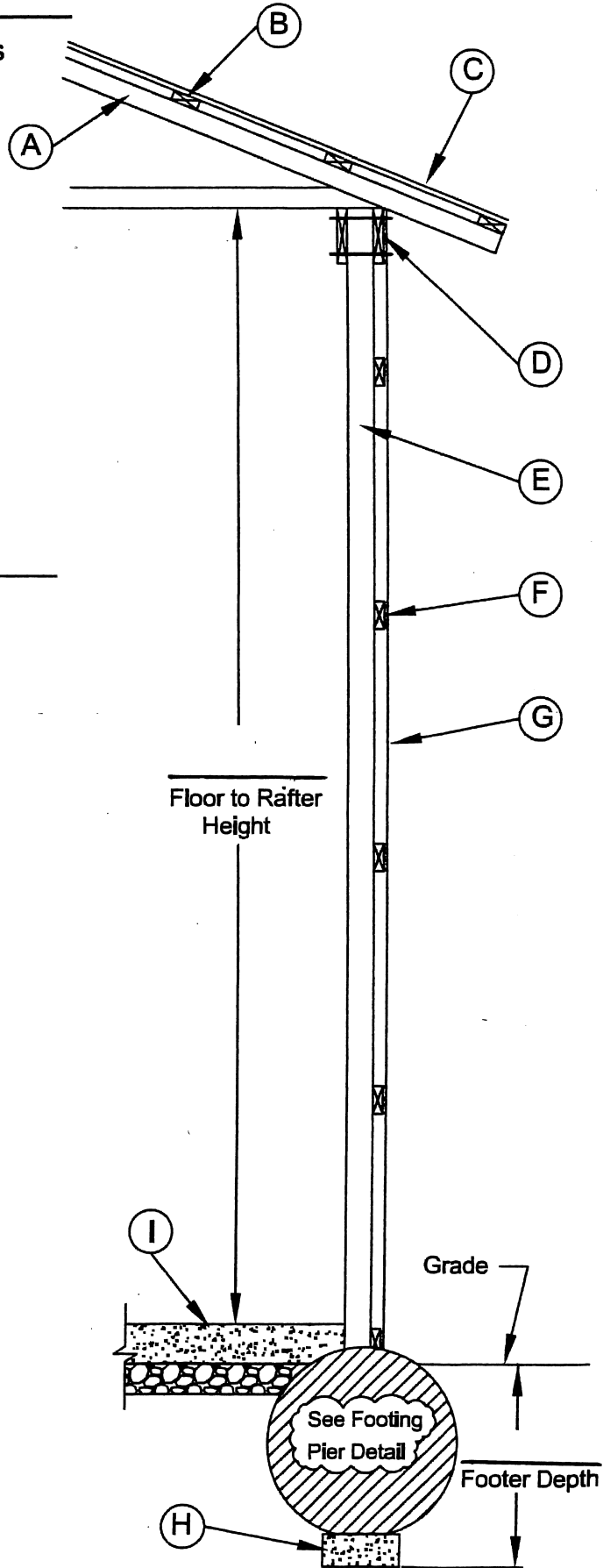

- (circle one)
- (A) RAFTERS or TRUSSES  
Type: \_\_\_\_\_ Pitch: \_\_\_\_\_  
Span: \_\_\_\_\_ Spacing: \_\_\_\_\_
  - (B) ROOF SHEATHING  
Type: \_\_\_\_\_ Thickness: \_\_\_\_\_  
Spacing: \_\_\_\_\_
  - (C) ROOF COVERING  
Type: \_\_\_\_\_
  - (D) HEADER / CARRIER BEAM  
Type: \_\_\_\_\_ Size: \_\_\_\_\_  
Span: \_\_\_\_\_ Fastening Method: \_\_\_\_\_
  - (E) POSTS  
Type: \_\_\_\_\_ Size: \_\_\_\_\_  
Spacing: \_\_\_\_\_
  - (F) WALL SHEATHING  
Type: \_\_\_\_\_ Spacing: \_\_\_\_\_
  - (G) WALL COVERING  
Type: \_\_\_\_\_
  - (H) FOOTER  
Width \_\_\_\_\_ x Length \_\_\_\_\_ x Thickness \_\_\_\_\_
  - (I) FLOOR  
Type: \_\_\_\_\_ Thickness: \_\_\_\_\_

## FOOTING PIERS ( Suggested Methods ) - Circle Method Used -

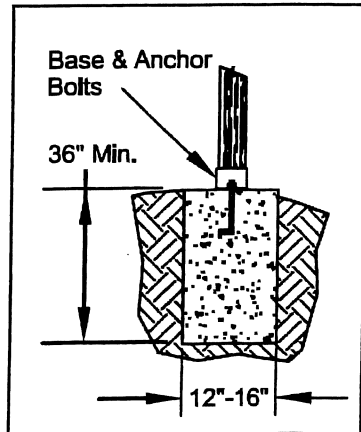
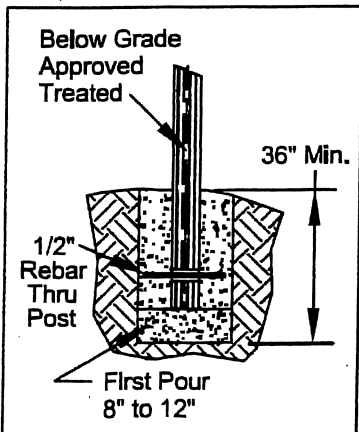

Permit No. \_\_\_\_\_

# Bureau Veritas North America, Inc.

## PERMIT APPLICATION

For questions or to submit your paperwork, please contact the office nearest you  
(locations attached)

Township or Borough: \_\_\_\_\_ Date: \_\_\_\_\_

Work Site Address: \_\_\_\_\_  
(street) (city) (state) (zip)

Owner/Applicant: \_\_\_\_\_ Phone: \_\_\_\_\_

Mailing Address: \_\_\_\_\_  
(street) (city) (state) (zip)

Contractor: \_\_\_\_\_ Phone: \_\_\_\_\_

Contractor Address: \_\_\_\_\_  
(street) (city) (state) (zip)

**TYPE OF WORK** (Please check either "Residential" or "Commercial" below and provide all information requested)

Residential Project: Description \_\_\_\_\_ Cost \$ \_\_\_\_\_

New Bldg. Square Footage All Floors: \_\_\_\_\_ (not including garage)

Finished Basement Square Footage (if applicable) \_\_\_\_\_

Office Use Only  
Use Group \_\_\_\_\_ Construction Type \_\_\_\_\_ Code Used \_\_\_\_\_

Commercial Project: Description \_\_\_\_\_ Cost \$ \_\_\_\_\_

New Building     Existing Building    New Bldg. Square Footage All Floors: \_\_\_\_\_

Use Group \_\_\_\_\_ Construction Type \_\_\_\_\_ Occupancy Load \_\_\_\_\_ Code Used \_\_\_\_\_

I hereby certify that the proposed work is authorized by the owner of record and that I am or have been authorized to make this application as his/her authorized agent and we agree to conform to all applicable laws of this jurisdiction.

Print Name \_\_\_\_\_

Signature \_\_\_\_\_ Date \_\_\_\_\_

OFFICE USE ONLY

Building Plan Review Date: \_\_\_\_\_

Approved

Not Approved

Plan Reviewer: \_\_\_\_\_

Permit Fee: \$ \_\_\_\_\_

OVER

**RIDGWAY BOROUGH MUNICIPAL PRIOR APPROVALS**

(To ensure that all local ordinances are complied with, this form must be completed by the applicant and signed by a Municipal Official prior to the issuance of a building permit by Bureau Veritas North America, Inc.)

Applicant/Property Owner: \_\_\_\_\_ Phone: \_\_\_\_\_

Mailing Address: \_\_\_\_\_

Contractor: \_\_\_\_\_ Phone: \_\_\_\_\_

Address: \_\_\_\_\_

Project Cost: \$ \_\_\_\_\_

Please check one below:

Residential Project: Description \_\_\_\_\_ Size: \_\_\_\_\_

Commercial Project: Description \_\_\_\_\_ Size: \_\_\_\_\_

Work Site Address: \_\_\_\_\_

*I hereby certify that the proposed work is authorized by the owner of record and that I have been authorized to make this application as his authorized agent and we agree to conform to all applicable laws of this jurisdiction.*

Signature: \_\_\_\_\_ Date: \_\_\_\_\_

**APPLICANT MUST HAVE BOROUGH COMPLETE THE FOLLOWING:**

Site Located Within Flood Plain? \_\_\_\_\_ Zoning Type \_\_\_\_\_

Type of Sewage: \_\_\_\_\_ (Approval Attached) Not Applicable

Type of Water: \_\_\_\_\_ (Approval Attached) Not Applicable

Road Occupancy Permit: \_\_\_\_\_ (Approval Attached) Not Applicable

Stormwater Management: \_\_\_\_\_ (Approval Attached) Not Applicable

**I hereby certify that this application is in compliance with all relevant ordinances of Ridgway Borough and therefore eligible for Municipal approval.**

Date Approved/Issued: \_\_\_\_\_

Borough Officer/Secretary: \_\_\_\_\_

**DIRECTION FORM**

ADDRESS OF PROJECT \_\_\_\_\_

BETWEEN \_\_\_\_\_ AND \_\_\_\_\_  
(cross street) (cross street)

PLEASE PROVIDE DETAILED INSTRUCTIONS ON HOW TO GET TO THE CONSTRUCTION LOCATION:

\_\_\_\_\_  
\_\_\_\_\_  
\_\_\_\_\_  
\_\_\_\_\_  
\_\_\_\_\_  
\_\_\_\_\_  
\_\_\_\_\_  
\_\_\_\_\_  
\_\_\_\_\_  
\_\_\_\_\_  
\_\_\_\_\_  
\_\_\_\_\_  
\_\_\_\_\_  
\_\_\_\_\_  
\_\_\_\_\_

***TO BE INCLUDED WITH EVERY BUILDING PERMIT APPLICATION***



**BUREAU VERITAS**  
**VERITAS**

## Bureau Veritas Office Locations - Pennsylvania

Western Pennsylvania	Eastern Pennsylvania
<b>Armstrong Office</b>	<b>Broomall Office</b>
204 Butler Road, Suite 3	790A Parkway Drive
Kittanning, PA 16201	Broomall, PA 19008
P: 724.548.1414	P: 877.392.9445
F: 724.548.1403	F: 877.392.9444
<b>Brookville Office</b>	<b>Pocono Office</b>
1514 Route 28	5510 Memorial Drive
Brookville, PA 15825	Tobyhanna, PA 18466
P: 814.849.2448	P: 570.894.2801
F: 814.849.0825	F: 570.894.2986
<b>Huntingdon Office</b>	<b>Wyoming Office</b>
10773 William Penn Highway, Suite D	184 Keiserville Road
Huntingdon, PA 16652	Tunkhannock, PA 18657
P: 814.643.3480	P: 570.836.7196
F: 814.643.3766	F: 570.836.5967
<b>Mifflin Office</b>	
821 Electric Avenue, Suite C	
Lewistown, PA 17044	
P: 717.242.0992	
F: 717.242.4391	
<b>Somerset Office</b>	
451 Stoystown Road, Suite 105B	
Somerset, PA 15501	
P: 814.701.2181	
F: 814.701.2182	